



YDS Hose Clamps

THE EXPERT IN SUPPLY FASTENERS



OUR QUALITY COMES FROM OUR
ATTENTION TO ALL THE DETAILS

www.ydsc.com.tw



Overview

As one of the leading manufacturer of hose clamps in Taiwan, we have always prided being “an excellent helpmeet to repairers.” We are devoted to providing tough, durable and safe hose clamps to enhance the operation quality of automobile, Building, Industry...etc.

YDS hose clamps “make us rest assured about the cars we repair,” said the purchasers of Auto shops; Hose clamp may be a small part in the auto repair market and mechanical shops; however, it indeed plays a critical role for normal operation of the equipment.

We pay attention to every detail and you pay for safety.

Milestone

- Year 1993 - Yung Des Shing Enterprise Ltd was Founded in 1993 with US\$100,000 in capital and 8 employees, focusing in mold design
- Year 1995 - Setting up the production lines of German type Hose Clamp
- Year 2000 - We registered own brand YDS and begin to expand the overseas markets
- Year 2004 - ISO 9001:2000 certification by UKAS (British AFAQ-EAQA Organization). Instead of Yung Des Shing Enterprise, EVEREON INDUSTRIES, INC. is our new name for new vision and expanding policy
- Year 2007 - ERP (Enterprise resource planning) implementation
- Year 2008 - With 110 employees, the output is more than 5,000,000 pieces per month
- Year 2009 - Opening a Branch in ShangHai China

Warehouse



ISO 9001:2008



Oil pressure



Pulling force



Product guide

ITEM	PART NO	STANDARD	MATERIAL
GERMAN STYLE HOSE CLAMP	Y121,Y122	GERMAN DIN3017	W2 (#430S.S)
	Y141,Y142	GERMAN DIN3017	W4 (#304S.S)
	Y152	GERMAN DIN3017	W5 (#316S.S)
AMERICAN STYLE HOSE CLAMP	Y221		W2 (#430S.S)
	Y241		W4 (#304S.S)
BUTTERFLY HOSE CLAMP	Y123		W2 (#430S.S)
WIRE HOSE CLAMP	Y311		S42C CHARCOAL STEEL
BUTTERFLY WIRE CLAMP	Y312,Y313		S42C CHARCOAL STEEL
CV BOOT CLAMP	Y421,Y422,Y423,Y424		#430 STAINLESS STEEL
MINI CLAMP	Y512,Y523		W2 (#430S.S) OR GALVANIZED
MICRO HOSE CLAMP	Y521		W2 (#430S.S)
EAR HOSE CLAMP	Y449		#304 STAINLESS STEEL
SCREWDRIVER	Y6001		IRON
DISPLAY BOARD	Y6101,Y6102,Y6103		IRON

German Style Hose Clamp (Non-Perforated Band)

Specification for series Y121 and Y122

Material(W2) : The housing and band are made of AISI430 S.S , but screw is Galvanized with RoHS compliant coating (Y121 & Y122)

Housing : Y121- Standard type , without weld on the back of housing

Y122 - Weld type, with weld on the back of housing

TYPE	Y121, Y122-09W	Y121, Y122-12W
Band Width (w)	9mm	12mm
Band Thickness (t)	0.6mm	0.7mm
Housing Width (B)	12mm	15mm
Housing Height (h)	11mm	11mm
Width Across Flats (SW)	7mm	7mm
SCREW	CROSS SLOTTED HEXAGON HEAD	

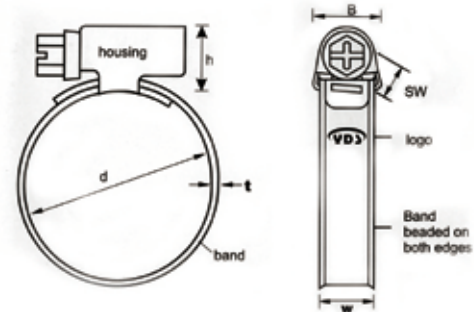

Part No.		Clamping Range			Tightening Torque Nm
Y121-09W SERIES (W2)	Y122-09W SERIES (W2)	Min. Dia. In MM	Max. Dia. In MM	Max. Dia. In INCH	
0.6T*9 Width band					
Y121-09W012	Y122-09W012	8	12	1/2"	Y121: 2.5-3.5
Y121-09W016	Y122-09W016	10	16	5/8"	
Y121-09W020	Y122-09W020	12	20	3/4"	
Y121-09W022	Y122-09W022	12	22	7/8"	
Y121-09W025	Y122-09W025	16	25	1"	
Y121-09W027	Y122-09W027	16	27	1-1/16"	
Y121-09W032	Y122-09W032	20	32	1-1/4"	
Y121-09W040	Y122-09W040	25	40	1-5/8"	Y122: 3.5-4.5
Y121-09W045	Y122-09W045	30	45	1-3/4"	
Y121-09W050	Y122-09W050	32	50	2"	
Y121-09W060	Y122-09W060	40	60	2-3/8"	
	Y122-09W070	50	70	2-3/4"	
	Y122-09W080	60	80	3-1/8"	
	Y122-09W090	70	90	3-1/2"	
	Y122-09W100	80	100	4"	



Application

Y121 can be used for connecting pipes of general industrial mechanical, advanced auto, and construction with low requirements in terms of corrosion resistance

Part No.		Clamping Range			Tightening Torque Nm
Y121-12W SERIES (W2)	Y122-12W SERIES (W2)	Min. Dia. In MM	Max. Dia. In MM	Max. Dia. In INCH	
0.7T*12 Width band					
Y121-12W025	Y122-12W025	16	25	1"	Y121: 3.5-4.5
Y121-12W027	Y122-12W027	16	27	1-1/16"	
Y121-12W032	Y122-12W032	20	32	1-1/4"	
Y121-12W040	Y122-12W040	25	40	1-5/8"	
Y121-12W045	Y122-12W045	30	45	1-3/4"	
Y121-12W050	Y122-12W050	32	50	2"	
Y121-12W060	Y122-12W060	40	60	2-3/8"	
Y121-12W070	Y122-12W070	50	70	2-3/4"	
Y121-12W080	Y122-12W080	60	80	3-1/8"	
Y121-12W090	Y122-12W090	70	90	3-1/2"	
Y121-12W100	Y122-12W100	80	100	4"	Y122: 4.5-5.5
Y121-12W110	Y122-12W110	90	110	4-3/8"	
Y121-12W120	Y122-12W120	100	120	4-3/4"	
Y121-12W130	Y122-12W130	110	130	5-1/8"	
Y121-12W140	Y122-12W140	120	140	5-1/2"	
Y121-12W150	Y122-12W150	130	150	5-7/8"	
Y121-12W160	Y122-12W160	140	160	6-1/4"	
Y121-12W170	Y122-12W170	150	170	6-3/4"	
Y121-12W180	Y122-12W180	160	180	7"	
Y121-12W190	Y122-12W190	170	190	7-1/2"	
Y121-12W200	Y122-12W200	180	200	7-7/8"	
Y121-12W210	Y122-12W210	190	210	8-3/4"	
Y121-12W220	Y122-12W220	200	220	9-1/2"	
Y121-12W230	Y122-12W230	210	230	9-1/8"	
Y121-12W240	Y122-12W240	220	240	9-2/5"	

Y121

Standard type



Y122

Weld type



The most popular item of all series, with the weld on the back of housing, the maximum sealing can be achieved even with extremely stressed hoses. It can be applied for transportation, moving machines, agriculture, industries

German Style Hose Clamp (Non-Perforated Band)

Specification for series Y141 and Y142

Material(W4) : All of the parts are made of #304S.S (Y141 & Y142)

Housing : Y141- Standard type , without weld on the back of housing

Y142 - Weld type, with weld on the back of housing

TYPE	Y141, Y142-09W	Y141, Y142-12W
Band Width (w)	9mm	12mm
Band Thickness (t)	0.6mm	0.7mm
Housing Width (B)	12mm	15mm
Housing Height (h)	11mm	11mm
Width Across Flats (SW)	7mm	7mm
SCREW	SLOTTED HEXAGON HEAD	

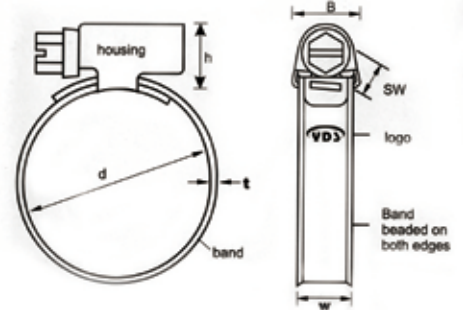

Part No.		Clamping Range			Tightening Torque Nm
Y141-09W SERIES (W4)	Y142-09W SERIES (W4)	Min. Dia. In MM	Max. Dia. In MM	Max. Dia. In INCH	
0.6T*9 Width band					
Y141-09W012	Y142-09W012	8	12	1/2"	Y141: 3.5-4.5
Y141-09W016	Y142-09W016	10	16	5/8"	
Y141-09W020	Y142-09W020	12	20	3/4"	
Y141-09W022	Y142-09W022	12	22	7/8"	
Y141-09W025	Y142-09W025	16	25	1"	
Y141-09W027	Y142-09W027	16	27	1-1/16"	
Y141-09W032	Y142-09W032	20	32	1-1/4"	
Y141-09W040	Y142-09W040	25	40	1-5/8"	
Y141-09W045	Y142-09W045	30	45	1-3/4"	
Y141-09W050	Y142-09W050	32	50	2"	
Y141-09W060	Y142-09W060	40	60	2-3/8"	
	Y142-09W070	50	70	2-3/4"	
	Y142-09W080	60	80	3-1/8"	
	Y142-09W090	70	90	3-1/2"	
	Y142-09W100	80	100	4"	

Part No.		Clamping Range			Tightening Torque Nm
Y141-12W SERIES (W4)	Y142-12W SERIES (W4)	Min. Dia. In MM	Max. Dia. In MM	Max. Dia. In INCH	
0.7T*12 Width band					
Y141-12W025	Y142-12W025	16	25	1"	Y141: 4.5-5.5
Y141-12W027	Y142-12W027	16	27	1-1/16"	
Y141-12W032	Y142-12W032	20	32	1-1/4"	
Y141-12W040	Y142-12W040	25	40	1-5/8"	
Y141-12W045	Y142-12W045	30	45	1-3/4"	
Y141-12W050	Y142-12W050	32	50	2"	
Y141-12W060	Y142-12W060	40	60	2-3/8"	
Y141-12W070	Y142-12W070	50	70	2-3/4"	
Y141-12W080	Y142-12W080	60	80	3-1/8"	
Y141-12W090	Y142-12W090	70	90	3-1/2"	
Y141-12W100	Y142-12W100	80	100	4"	
Y141-12W110	Y142-12W110	90	110	4-3/8"	
Y141-12W120	Y142-12W120	100	120	4-3/4"	
Y141-12W130	Y142-12W130	110	130	5-1/8"	
Y141-12W140	Y142-12W140	120	140	5-1/2"	
Y141-12W150	Y142-12W150	130	150	5-7/8"	
Y141-12W160	Y142-12W160	140	160	6-1/4"	
Y141-12W170	Y142-12W170	150	170	6-3/4"	
Y141-12W180	Y142-12W180	160	180	7"	
Y141-12W190	Y142-12W190	170	190	7-1/2"	
Y141-12W200	Y142-12W200	180	200	7-7/8"	
Y141-12W210	Y142-12W210	190	210	8-3/4"	
Y141-12W220	Y142-12W220	200	220	9-1/2"	
Y141-12W230	Y142-12W230	210	230	9-1/8"	
Y141-12W240	Y142-12W240	220	240	9-2/5"	



Y141

Standard type



Y141 can withstand extreme acidity and alkalinity, which are used for dangerous and difficult environment or demanded for high security, such as for top grade mechanical engineering, agricultural machinery

Y142

Weld type



German Style Hose Clamp (Non-Perforated Band)

Specification for series Y152

Material(W5) : All of the parts are made of #316S.S

Housing : Weld type, with weld on the back of housing

TYPE	Y152-09W	Y152-12W
Band Width (w)	9mm	12mm
Band Thickness (t)	0.6mm	0.7mm
Housing Width (B)	12mm	15mm
Housing Height (h)	11mm	11mm
Width Across Flats (SW)	7mm	7mm
SCREW	SLOTTED HEXAGON HEAD	

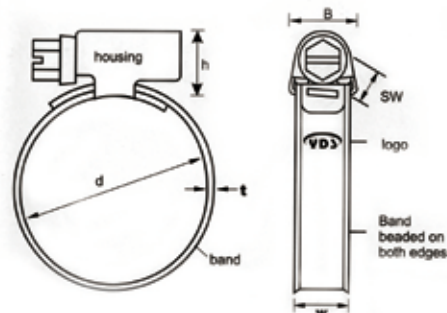

Part No.	Clamping Range			Tightening Torque Nm
	Min. Dia. In MM	Max. Dia. In MM	Max. Dia. In INCH	
Y152-09W SERIES (W5)				Y152: 5.5-6.5
0.6T*9 Width band				
Y152-09W012	8	12	1/2"	
Y152-09W016	10	16	5/8"	
Y152-09W020	12	20	3/4"	
Y152-09W022	12	22	7/8"	
Y152-09W025	16	25	1"	
Y152-09W027	16	27	1-1/16"	
Y152-09W032	20	32	1-1/4"	
Y152-09W040	25	40	1-5/8"	
Y152-09W045	30	45	1-3/4"	
Y152-09W050	32	50	2"	
Y152-09W060	40	60	2-3/8"	
Y152-09W070	50	70	2-3/4"	
Y152-09W080	60	80	3-1/8"	
Y152-09W090	70	90	3-1/2"	
Y152-09W100	80	100	4"	

Part No.	Clamping Range			Tightening Torque Nm
	Min. Dia. In MM	Max. Dia. In MM	Max. Dia. In INCH	
Y152-12W SERIES (W5)				Y152: 6.5-7.5
0.7T*12 Width band				
Y152-12W025	16	25	1"	
Y152-12W027	16	27	1-1/16"	
Y152-12W032	20	32	1-1/4"	
Y152-12W040	25	40	1-5/8"	
Y152-12W045	30	45	1-3/4"	
Y152-12W050	32	50	2"	
Y152-12W060	40	60	2-3/8"	
Y152-12W070	50	70	2-3/4"	
Y152-12W080	60	80	3-1/8"	
Y152-12W090	70	90	3-1/2"	
Y152-12W100	80	100	4"	
Y152-12W110	90	110	4-3/8"	
Y152-12W120	100	120	4-3/4"	
Y152-12W130	110	130	5-1/8"	
Y152-12W140	120	140	5-1/2"	
Y152-12W150	130	150	5-7/8"	
Y152-12W160	140	160	6-1/4"	
Y152-12W170	150	170	6-3/4"	
Y152-12W180	160	180	7"	
Y152-12W190	170	190	7-1/2"	
Y152-12W200	180	200	7-7/8"	
Y152-12W210	190	210	8-3/4"	
Y152-12W220	200	220	9-1/2"	
Y152-12W230	210	230	9-1/8"	
Y152-12W240	220	240	9-2/5"	



Y152

Weld type



Screw coating options

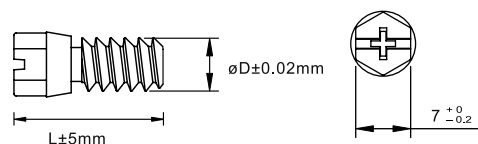

American Style Hose Clamp (Perforated Band)

Specification for series Y221 and Y241

Material :

Y221 - The Housing and Band are made of AISI430 S.S , but Screw is Galvanized with RoHS compliant coating

Y241 - All of the parts are made of #304S.S

Housing : Standard type , without weld on the back of housing(Y221&Y241)

TYPE	Y221, Y241-08W	Y221, Y241-127W
Band Width (w)	8mm	12.7mm
Band Thickness (t)	0.6mm	0.6mm
Housing Width (B)	10.2mm	16.1mm
Housing Height (h)	8.3mm	10.7mm
Width Across Flats (SW)	6mm	8mm
SCREW	-	

Part No.		Clamping Range			Tightening Torque Nm
Y221-08W SERIES (W2)	Y241-08W SERIES (W4)	Min. Dia. In INCH	Max. Dia. In INCH	Max. Dia. In MM	
0.6T*8 Width band					
Y221-08W016	Y241-08W016	1/4	5/8	16	Y221: 2.0-3.0
Y221-08W022	Y241-08W022	5/16	7/8	22	
Y221-08W025	Y241-08W025	3/8	1	25	
Y221-08W027	Y241-08W027	3/8	1-1/16	27	Y241: 3.0-4.0

Part No.		Clamping Range			Tightening Torque Nm
Y221-127W SERIES (W2)	Y241-127W SERIES (W4)	Min. Dia. In INCH	Max. Dia. In INCH	Max. Dia. In MM	
0.7T*12.7 Width band					
Y221-127W027	Y241-127W027	1/2	1-1/16	27	Y221: 2.5-3.5
Y221-127W032	Y241-127W032	1/2	1-1/4	32	
Y221-127W038	Y241-127W038	1-1/16	1-1/2	38	
Y221-127W044	Y241-127W044	3/4	1-3/4	44	
Y221-127W051	Y241-127W051	1	2	51	
Y221-127W057	Y241-127W057	1-1/4	2-1/4	57	
Y221-127W063	Y241-127W063	1-1/2	2-1/2	63	
Y221-127W070	Y241-127W070	1-3/4	2-3/4	70	
Y221-127W076	Y241-127W076	2	3	76	
Y221-127W082	Y241-127W082	2-1/4	3-1/4	82	
Y221-127W095	Y241-127W095	2-3/4	3-3/4	95	Y241: 3.5-4.5
Y221-127W101	Y241-127W101	3	4	101	
Y221-127W108	Y241-127W108	3-1/4	4-1/4	108	
Y221-127W114	Y241-127W114	2-1/2	4-1/2	114	
Y221-127W127	Y241-127W127	3	5	127	
Y221-127W140	Y241-127W140	3-1/2	5-1/2	140	
Y221-127W152	Y241-127W152	4	6	152	
Y221-127W165	Y241-127W165	4-1/2	6-1/2	165	
Y221-127W178	Y241-127W178	5	7	178	

Y221

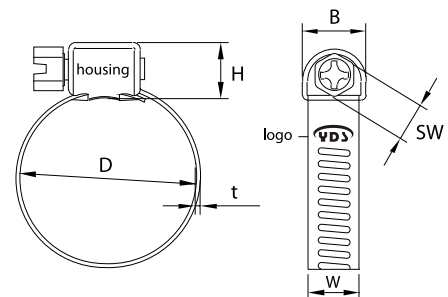

Y241

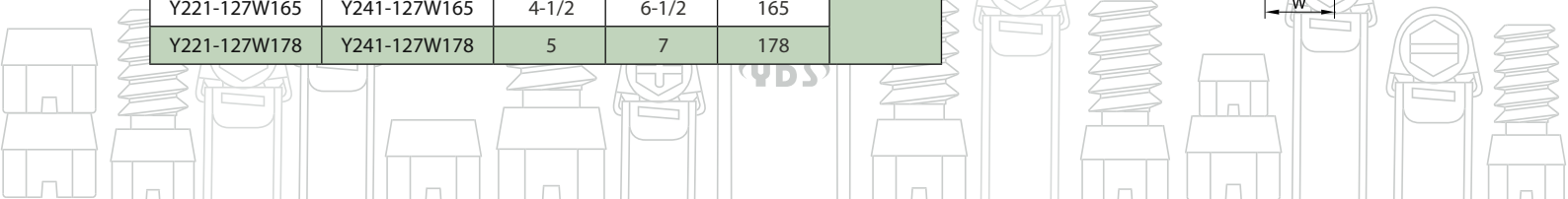
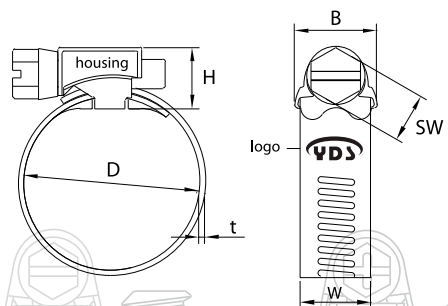

Butterfly Hose Clamp

Specification for series Y123

Material(W2): The housing and band of clamps are made up of AISI 430S.S
but the screw is made up of yellow chromate carbon steel

Housing : Without weld

Grip : Blue, green, yellow , orange , red , black for plastic handle

Part No.	Clamping Range			GRIP/ STANDARD COLOR	Q'TY Pc/ctn	WEIGHT		CUFT
	Min. Dia. MM	Max. Dia. MM	Max. Dia. INCH			N.W. k.g	G.W. k.g	
0.6T*9Width band								
Y123-09W012	8	12	1/2"	Blue	2000	23.7	25.3	1.2
Y123-09W016	10	16	5/8"	Orange	2000	24.2	25.8	1.2
Y123-09W020	12	20	3/4"	Green	1000	12.8	14.4	1.3
Y123-09W022	12	22	7/8"	Yellow	1000	13.1	14.8	1.3
Y123-09W025	16	25	1"	Blue	1000	13.7	15.3	1.3
Y123-09W027	16	27	1-1/16"	Orange	1000	14.6	16.2	1.3
Y123-09W032	20	32	1-1/4"	Blue	1000	15.6	17.2	1.3
Y123-09W035	20	35	1-2/5"	Blue	1000	16.2	17.8	1.3
Y123-09W040	25	40	1-5/8"	Blue	1000	16.8	18.6	2.0
Y123-09W045	30	45	1-3/4"	Blue	1000	17.1	19.2	2.3
Y123-09W050	32	50	2"	Blue	1000	18.2	20.2	2.3
Y123-09W060	40	60	2-3/8"	Blue	1000	20.9	23.1	2.3
Y123-09W070	50	70	2-3/4"	Blue	1000	25.2	27.8	3.3

Y123



Application

Light and handy design of plastic grip with zebra ring can make users take their ease to roll the clamps without using any auxiliary tools. It can be very efficient and save your money. It is the best choice for household or DIY users.

Mini Clamp

Specification for series Y512,Y523

Material:

Y512 - All parts are made up of galvanized , 9mm band width , band thickness is 0.5mm

Y523 - All parts are made up of AISI 430 stainless steel, 9mm band width , band thickness is 0.5mm

Part No.	Size mm	Clamping Range		Screw	Tightening Torque Nm	
		Min. Dia. MM	Max. Dia. MM			
Y-512-09WM16	Y-523-09WM16	16	15	17.0	M4x16	1.5

Additional sizes available upon request

Y512



Micro Hose Clamp

Specification for series Y521

Material(W2): The housing and band of clamps are made up of AISI 430S.S but the screws are made up of galvanized with RoHS compliant coating

Housing : Without weld

Part No.	Clamping Range		Screw	Tightening Torque Nm
	Min. Dia. MM	Max. Dia. MM		
Y521-0711	7	11	4.8mm	0.5
Y521-1019	10	19	4.8mm	0.5

Additional sizes available upon request

Y521



Wire Hose Clamp

Specification for series Y311, 312, 313

Material:

Y311 - Wire hose clamp is made up of S42C charcoal steel

Y312 - Globular wire hose clamp is made up of S42C charcoal steel with flat handle

Y313 - Wire butterfly is made up of S42C charcoal steel with plastic handle (POM).

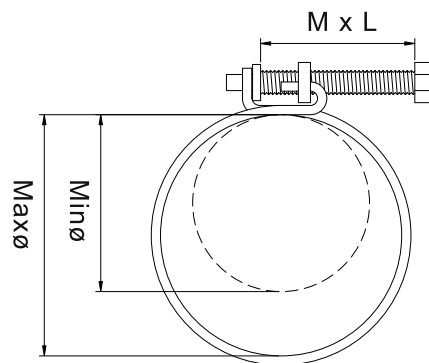

Y311



Wire Hose Clamp

Y312



Globular Wire Hose Clamp

Y313



Wire Butterfly Hose Clamp

Part No.			Clamping Range			Screw (MxL)	Wire Path
Y311	Y312	Y313	Min. Dia. MM	Max. Dia. MM	Max. Dia. INCH		
Y311-16D10	Y312-16D10	Y313-16D10	7	10	3/8"	M5x25	Ø1.6
Y311-16D13	Y312-16D13	Y313-16D13	10	13	1/2"		
Y311-16D16	Y312-18D16	Y313-18D16	13	16	5/8"		
Y311-18D19	Y312-18D19	Y313-18D19	14	19	3/4"	M5x30	Ø1.8
Y311-18D23	Y312-18D23	Y313-18D23	18	23	7/8"		
Y311-18D26	Y312-18D26	Y313-18D26	21	26	1"		
Y311-20D32	Y312-20D32	Y313-20D32	25	32	1-1/4"	M6x38	Ø2.0
Y311-20D38	Y312-20D38	Y313-20D38	31	38	1-1/2"		
Y311-20D45	Y312-20D45	Y313-20D45	38	45	1-3/4"		
Y311-20D51	Y312-20D51	Y313-20D51	44	51	2"	M6x48	Ø2.3
Y311-23D57	Y312-23D57	Y313-23D57	47	57	2-1/4"		
Y311-23D64	Y312-23D64	Y313-23D64	54	64	2-1/2"		
Y311-23D70	Y312-23D70	Y313-23D70	60	70	2-3/4"		
Y311-23D76	Y312-23D76	Y313-23D76	66	76	3"		
Y311-23D83	Y312-23D83	Y313-23D83	73	83	3-1/4"		
Y311-23D89	Y312-23D89	Y313-23D89	79	89	3-1/2"		
Y311-23D96	Y312-23D96	Y313-23D96	86	96	3-3/4"		
Y311-23D102	Y312-23D102	Y313-23D102	92	102	4"		
Y311-23D108	Y312-23D108	Y313-23D108	98	108	4-1/4"		
Y311-23D114	Y312-23D114	Y313-23D114	104	114	4-1/2"		
Y311-23D122	Y312-23D122	Y313-23D122	112	122	4-3/4"		
Y311-23D127	Y312-23D127	Y313-23D127	117	127	5"		
Y311-23D133	Y312-23D133	Y313-23D133	123	133	5-1/4"		
Y311-23D140	Y312-23D140	Y313-23D140	130	140	5-1/2"		
Y311-23D152	Y312-23D152	Y313-23D152	142	152	6"		
Y311-23D165	Y312-23D165	Y313-23D165	155	165	6-1/2"		
Y311-23D178	Y312-23D178	Y313-23D178	168	178	7"		
Y311-23D204	Y312-23D204	Y313-23D204	194	204	7-1/2"		

CV Boot Clamp

Specification for series Y421, 422, 423, 424

Material:

Y421 - All parts are made up of #430S.S

Y422 - All parts are made up of #430S.S

Y423 - All parts are made up of #430S.S

Y424 - All parts are made up of #430S.S

Material #304S.S is available for requirement

Part No.	Thickness MM	Width MM	Total Length	Max Dia/mm	
				Once Around	Twice Around
Y421-64W360	0.3	6.4	360mm	50	25
Y421-64W740	0.3	6.4	740mm	110	70
Y422-70W160	0.5	7.0	160mm	38	25
Y422-70W360	0.5	7.0	360mm	102	75
Y422-80W425	0.6	8.0	425mm	115	45
Y423-63W160	0.5	6.3	160mm	38	27
Y423-80W425	0.6	8.0	425mm	115	45
Y424-70W245	0.5	7.0	245mm	58	32
Y424-70W405	0.5	7.0	405mm	110	73

* Length can be requested by client's request

What is CV-Joints?

The Constant Velocity (CV) Joints is responsible a maintenance task for car axle . The axle transmits torque from the engine and transmission to drive the vehicle's wheels, not only transmitting power but also flexing flex up and down with the motion of the wheels over the road.

Y421



0.3X6.4X740MM

0.3X6.4X360MM

Y422



0.5X7X160MM

0.6X8X425MM

Y423



0.6X8X425MM

0.5X6.3X160MM

Y424



0.5X7X245MM

0.5X7.0X405MM



PART NO Y6005 For Y421



PART NO YF6303 For Y422,Y423,Y424



Ear Hose Clamp

Specification for series Y449

Material(W4): All parts are made up of #304S.S



Part No.	Clamping Range		Band width/mm	Band thickness/mm
	Min. Dia. MM	Max. Dia. MM		
Y449-10.5	8.8	10.5	5	0.5
Y449-11.3	9.6	11.3	5	0.5
Y449-13.3	10.8	13.3	7	0.6
Y449-15.3	12.8	15.3	7	0.6

Additional sizes available upon request

Application

Connect quickly, economic offer
 For many industries, dispensing equipment,
 Building, electronic industry, ship building,
 Food industries, chemicals...etc.



Tool For Ear Clamp

Customized Products

Y129



Y144



Y144F



Y144G



Y426



Y246

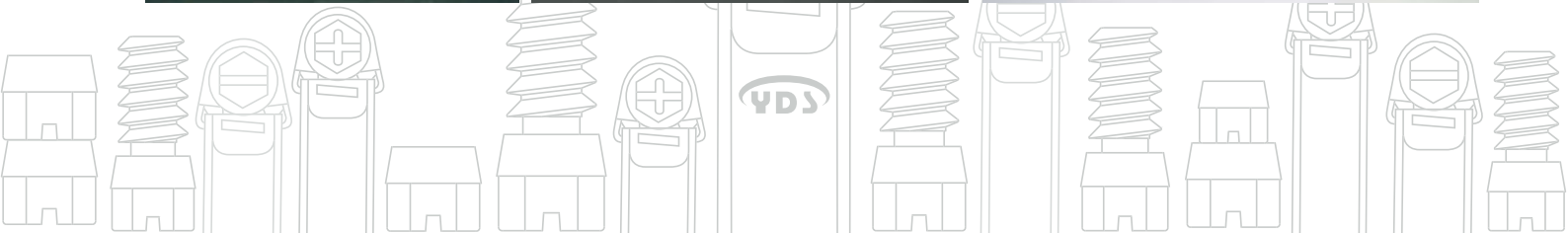

Display/tool

Series Y6101
12 Sizes , 120pcs

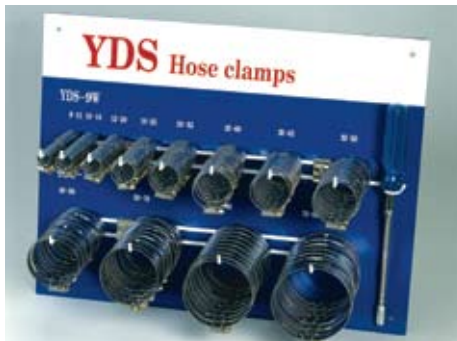

Series Y6102
10 Sizes , 100pcs

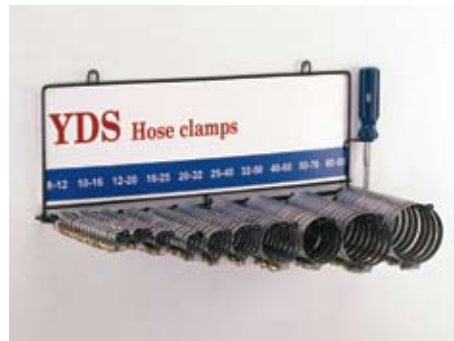

Series Y6103
11 Sizes , 110pcs



Y6001



Packaging

Bulk Packing /inner Box
Green Inner Box



Blue Inner Box/100pcs



Small Packing/10pcs



Blister Cards



Plastic bag is also available

FOR FURTHER INFORMATION PLEASE CONTACT US

GERMAN



MINI



WIRE

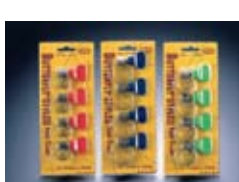

CV-JOINTS



MICRO



ACCESSORY

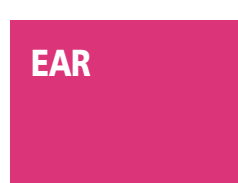

EVEREON



YDS



THE TOP IN TAIWAN

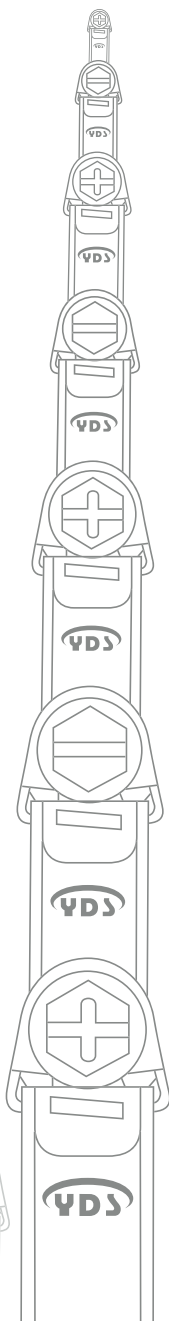

EVEREON INDUSTRIES, INC.

YUNG DES SHING ENTERPRISE CO., LTD

NO.86 Fuchian St. Taichung 404 Taiwan R.O.C

TEL:886-4-23953978 FAX:886-4-23959524

Website:www.ydsco.com.tw

E-mail:ydsco@ms41.hinet.net

